

THIS DRAWING IS UNPUBLISHED. RELEASED FOR PUBLICATION  
 © COPYRIGHT BY TYCO ELECTRONICS CORPORATION. ALL RIGHTS RESERVED.

LOC		DIST		REVISIONS					
AJ		16		P	LTR	DESCRIPTION	DATE	DWN	APVD
				M		REVISED PER EC 0514-0456-04	13DEC05	BL	JL

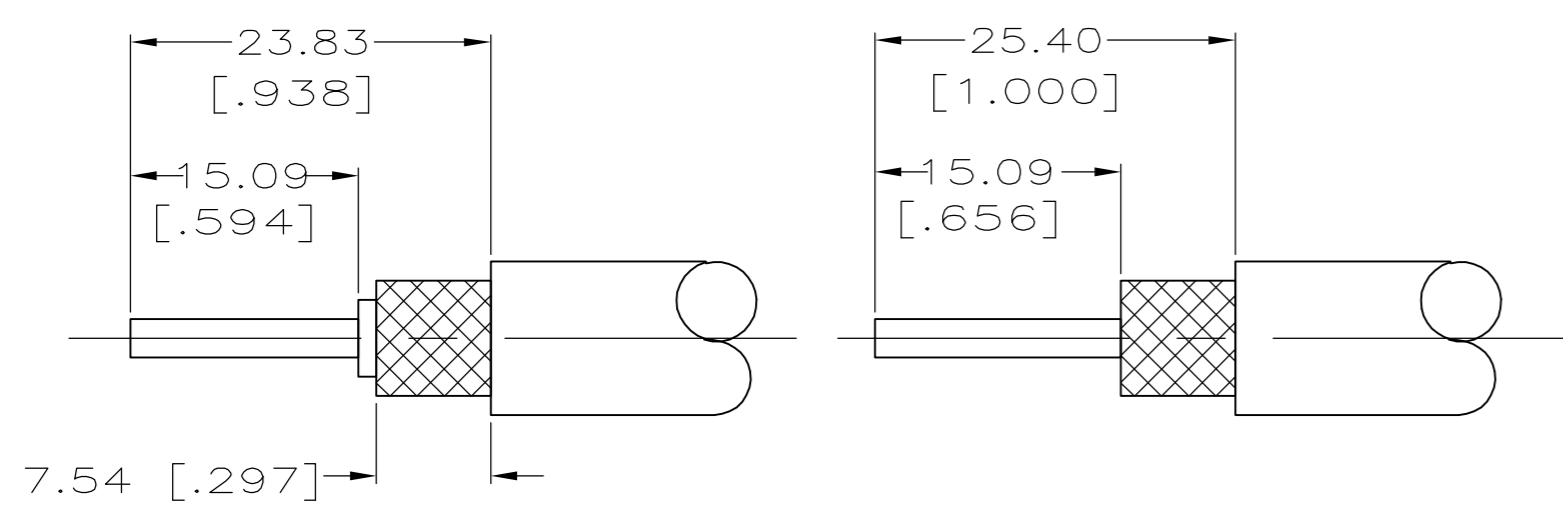
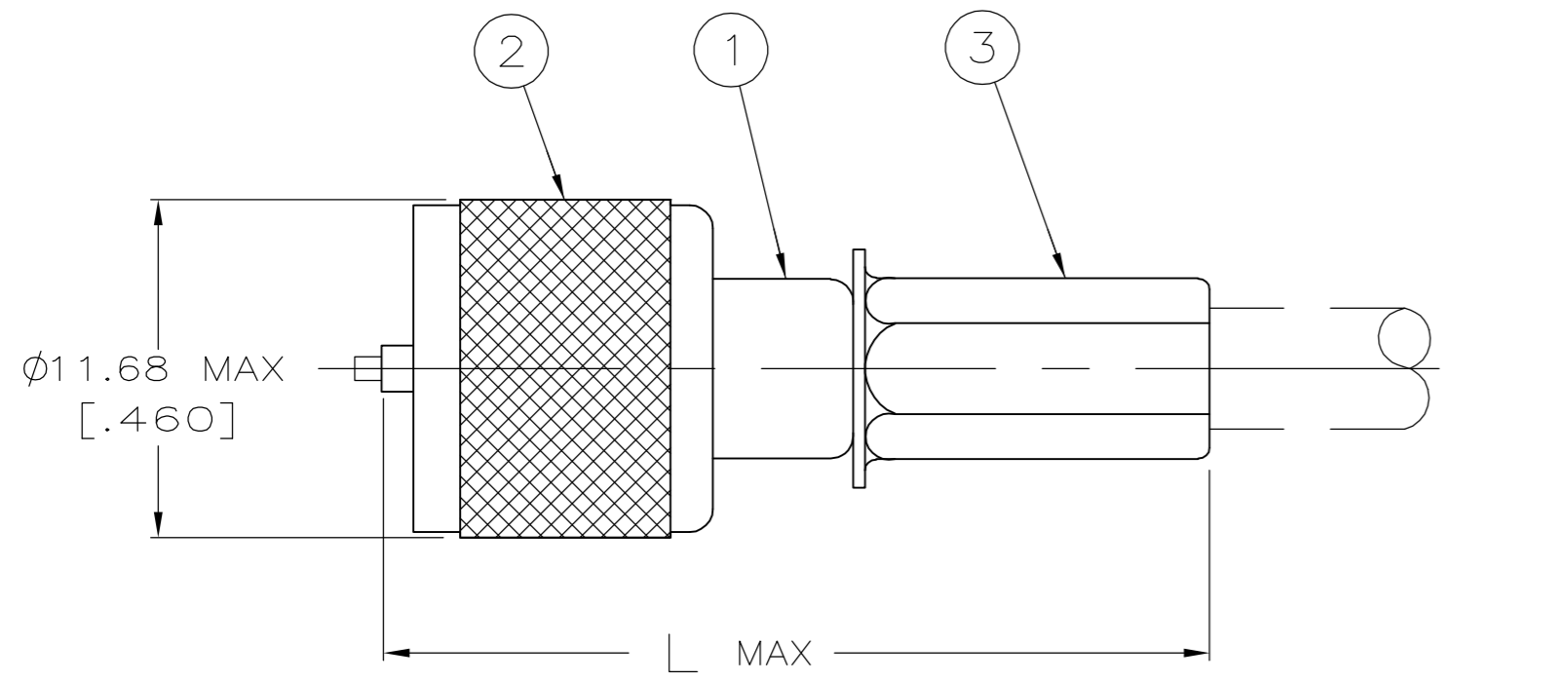

DETAIL A                      DETAIL B  
 RECOMMENDED STRIP LENGTH

- ① RG-59/U, RG-62/U, RG-124, RG-140, RG-210 AND BELDEN 9291, 9209 & 9268
- ② SEE SEPARATE RESTRICTED CUSTOMER DRAWING
- ③ RG-58/U, RG-58A/U, RG-58B/U, AND RG-58C/U
- ④ USE CRIMPING TOOL: 220149-1
- ⑤ USE AMP-O-ELECTRIC MACHINE 220152-1 WITH DIE 220166-1
- ⑥ SPECIAL PACKAGING: INDIVIDUALLY PACKAGED IN PREPRINTED BAGS WITH SPECIAL GRAPHIC
- ⑦ SEE INSTRUCTION SHEET I.S.2578
- ⑧ SEE INSTRUCTION SHEET I.S.2660
- ⑨ BULK PACKED

OBSOLETE	⑦ ⑨	28.96 [1.140]	A	④	③	226599-7	226598-4	226603-4	1-226600-2
	②	-	-	-	-	-	-	-	1-226600-1
	②	-	-	-	-	-	-	-	1-226600-0
	⑥ ⑦	28.96 [1.140]	A	④	③	226599-7	226598-4	226603-4	226600-9
	⑦	28.96 [1.140]	A	④	③	226599-6	226598-3	226603-2	226600-8
	-	-	-	-	-	-	-	-	-
	⑥ ⑦	28.96 [1.140]	A	④	③	226599-2	226598-2	226603-1	226600-6
OBSOLETE	②	-	-	-	-	-	-	-	226600-5
	-	-	-	-	-	-	-	-	-
	-	-	-	-	-	-	-	-	-
OBSOLETE	⑧	30.94 [1.218]	B	⑤	①	226708-2	226598-2	226707-1	226600-2
	⑦ ⑨	28.96 [1.140]	A	④	③	226599-2	226598-2	226603-1	226600-1
	REMARKS	L	STRIPPING SEE DETAIL	CRIMPING TOOL	FOR USE WITH CABLE	③ FERRULE QTY=1	② COLLAR QTY=1	① PLUG ASSY QTY=1	PART NO

THIS DRAWING IS A CONTROLLED DOCUMENT.

DWN	M. SNEED	6-14-91
CHK	R. HENRY	6-14-91
APVD	-	-
PRODUCT SPEC	-	
APPLICATION SPEC	-	
WEIGHT	-	
CUSTOMER DRAWING	-	

TOLERANCES UNLESS OTHERWISE SPECIFIED:

0 PLC	± -
1 PLC	± -
2 PLC	± -
3 PLC	± 0.41 [.016]
4 PLC	± -
ANGLES	± -
FINISH	-

tyco Electronics  
 Tyco Electronics Corporation  
 Harrisburg, PA 17105-3608

PLUG, MINIATURE UHF

SIZE	CAGE CODE	DRAWING NO	RESTRICTED TO
A2	00779	C=226600	-
SCALE	4:1	SHEET	1 OF 1
REV	M		

226600

A